

# Study Guide Review & Addendum

This Power Point was developed to aid prospective blasters in preparing for the Kentucky Blaster License Exam. The study guide was compiled many years ago and does not reflect modern technologies and methods. This Addendum covers material on the test which is not covered in the Study Guide or Laws and Regulations. It also contains additional info on subjects which are in the Study Guide such as calculations for electrical circuits, loading factors, cubic yardage, etc.

# Study Guide Review & Addendum

Electric Circuit Formulas

Blast Design Formulas

ANFO Properties

Blast Affects

Ground vibration & Air Overpressure

Seismic Monitoring

# Electric Circuit Formulas and Resistance Tables

- The total resistance of blasting circuit is made up of the resistance of the blasting cap, connecting wire used and firing line.
- To calculate resistance depends on length, thickness and type of metal wire.
- Electrical resistance is measured in terms of ohm's
- **Lead line** is normally duplex.
- **Bus wire** connected to the legwires of electric caps not for reuse.
- **Connecting wire** are used between the cap and lead wire or between the bus wire and leading wire
- **leading wire or firing cable** are used between the electric powder source and the electric blasting cap circuit.

# Nominal resistance of Electric Blasting caps with copper leg wires

Wire length (ft)	Resistance (ohms)	Wire length (ft)	Resistance (ohms)
4	1.4	24	2.3
6	1.6	28	2.4
8	1.7	30	2.2
10	1.8	40	2.3
12	1.8	50	2.6
16	1.9	60	2.8
20	2.1	80	3.3

# RESISTANCE OF WIRE

- Wire Resistance = (length of wire (ft) ÷ 1000) X Resistance from table.  
(table gives resistance per 1,000 feet of various gauge wire)

Gauge	6	8	10	12	14	16	18	20	22
Resistance	.395	.628	.999	1.59	2.53	4.02	6.39	10.15	16.1

- What is the resistance of 500 ft. of 18 gauge single conductor connecting wire?
- $(500 \div 1000) \times 6.39 =$
- $0.5 \times 6.39 = 3.19 \text{ ohms}$

# Series circuit

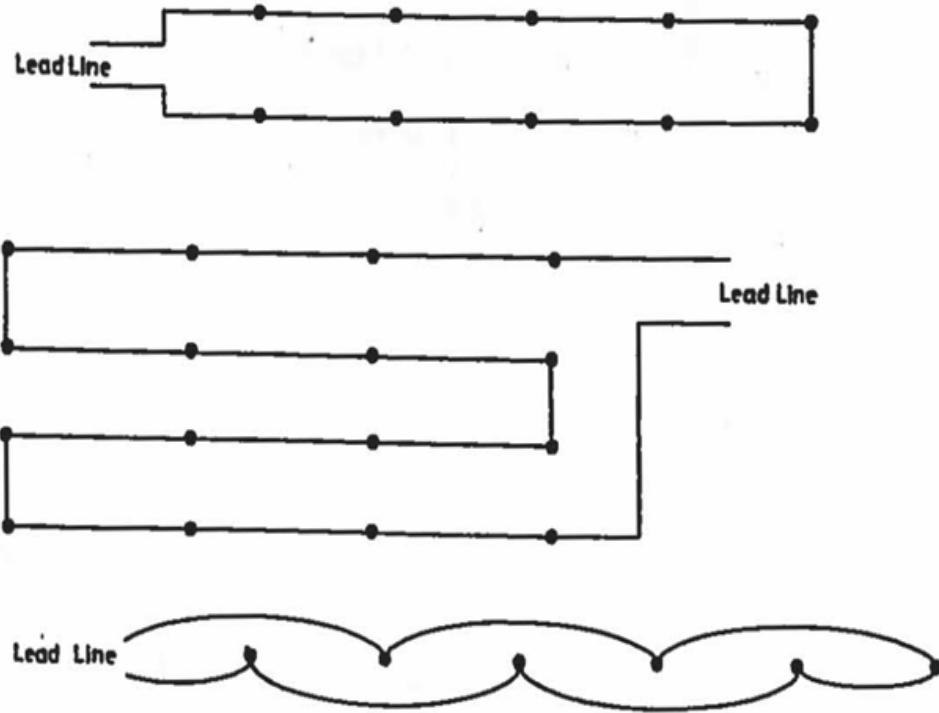

- The most basic blasting circuit.
- Series circuit is one which there is only one path or loop for the firing current to travel.
- The current is the same through each resistor.

# Calculating resistance in a Single Series

- Total Resistance =  $R_1 + R_2 + R_3 + R_4 + R_5$
- A small blasting circuit, consisting of 5 caps, is wired as a single series. If each cap has a resistance of 2.3 ohms, what is the total resistance of the circuit?
- $2.3 + 2.3 + 2.3 + 2.3 + 2.3 = 11.5 \text{ ohms}$

# Parallel Circuit

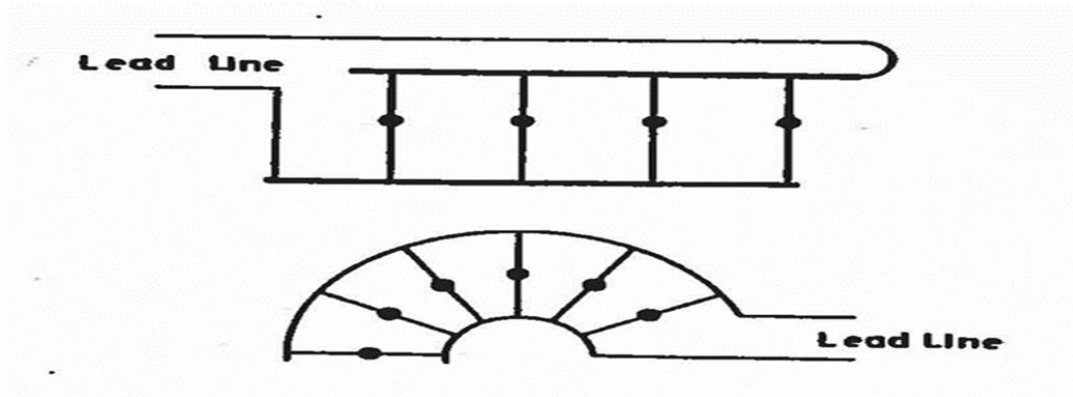

- Parallel Circuit - has two or more paths for current to flow through. Voltage is the same across each component of the parallel circuit. The sum of the currents through each path is equal to the total current that flows from the source.
- Each component then provides a separate path for the current.

# Calculating resistance in a parallel Series

$$\text{Formula } \frac{1}{\text{Total resistance}} = \frac{1}{R1} + \frac{1}{R2} + \frac{1}{R3} \dots$$

Four caps, each having 2.3 resistance, are connected in parallel.  
What is the total resistance of the circuit?

Solution:

$$\frac{1}{\text{TR}} = \frac{1}{2.3} + \frac{1}{2.3} + \frac{1}{2.3} + \frac{1}{2.3} = \frac{4}{2.3}$$

$$\text{Invert} = \frac{2.3}{4} \quad 0.57 \text{ ohms}$$

# Series-parallel circuit

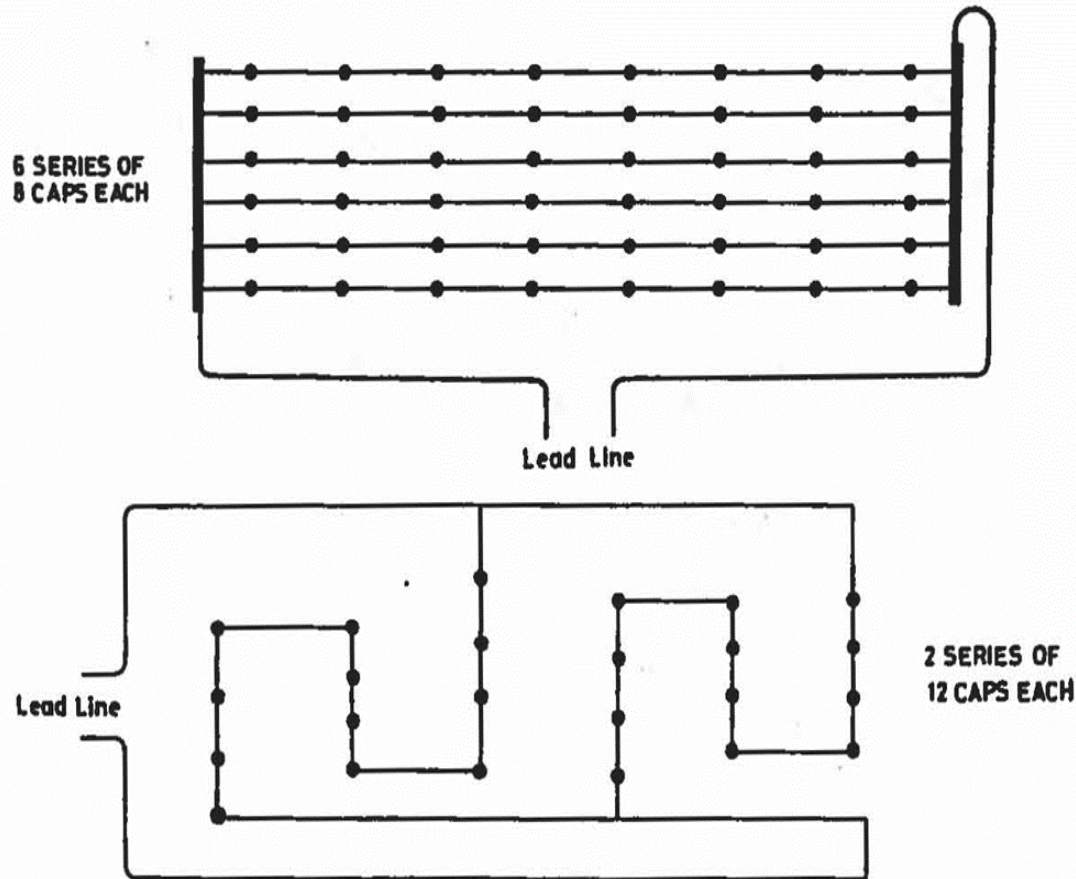

Series connected in parallel are connected along multiple paths so that the current can split up; the same voltage is applied to each series.

This method decreases the total resistance of the circuit and increases the total number of caps that a blasting machine can detonate.

# Calculating Resistance in a Series Parallel Circuit

- To calculate the resistance in a series-parallel circuit requires two separate operations.
- First calculate the resistance for each single series.
- Then the resistance of these series are combined using the formula for resistance in parallel circuit.
- We have 3 series wired in series parallel circuit with 3 blasting caps each with a resistance of 2.3 ohms. What is the resistance for the circuit?

series circuit  $R_t = R_1 + R_2 + R_3$

$$R_t = 2.3 + 2.3 + 2.3 \quad R_t = 6.9 \text{ ohms}$$

Parallel circuit  $\frac{1}{R_t} = \frac{1}{R_1} + \frac{1}{R_2} + \frac{1}{R_3}$

$$\frac{1}{R_t} = \frac{1}{6.9} + \frac{1}{6.9} + \frac{1}{6.9} \quad \underline{3} \text{ invert } \frac{6.9}{3} =$$
$$R_t = 2.3 \text{ ohms}$$

# Calculating Current in a blasting Circuit using Ohm' Law

- What is Ohm's Law?
- Ohm's Law is a formula used to calculate the relationship between voltage, current and resistance in an electrical circuit.
- To students of electronics, Ohm's Law ( $E = IR$ ) is as fundamentally important as Einstein's Relativity equation ( $E = mc^2$ ) is to physicists.
- When spelled out, it means, voltage = current x resistance (Ohm's Law symbol are, Voltage-E-Volt (V), Current-I-Ampere (A) and Resistance-R-Ohm  $\Omega$ )

# Ohm's Law Triangle

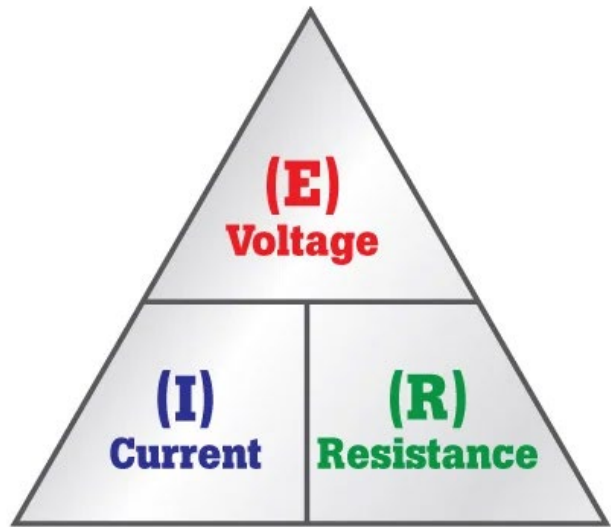

$$R = \frac{E}{I}$$



$$I = \frac{E}{R}$$



$$E = IR$$

Ohm's law for blasting operation is applicable only when shooting with power lines. The voltage supplied from a condenser discharge blasting machine is not a constant value. **Use ohm's law to solve the following.**

1. A blasting circuit has a total resistance of 75 ohm's if it is to be shot from 120 volt powder line, what is the current flowing in the circuit?

$$I(\text{current}) = E(\text{voltage}) \div R (\text{ohm's}) \text{ so } I = 120 \div 75, \mathbf{I=1.6 \text{ amps}}$$

2. A current of 2.5 amps is flowing in a blasting circuit having a resistance of 75 ohm's. What is the voltage of the powder supplying this?

$$E = I \times R \text{ so } E = 2.5 \text{ amps} \times 75 \text{ ohm's}, \mathbf{E=187.5 \text{ volts}}$$

3. Series of electric caps are connected to a 120 volt powder line and draws 23 amps of current. What is the net resistance of the series.

$$R = E \div I \text{ so } R = 120 \div 23, \mathbf{R=5.2 \text{ ohm's}}$$

# Rock Density

- Rock density is its mass per unit volume. Blasters use rock density to design proper powder factor.
- Density is also important when converting rock volume to weights for blast log reporting.
- A good indicator of rock hardness is drill penetration rate.
- Burn hole- A single hole left open to provide a free face for the adjacent loaded blast hole

# Apparent Burden and Spacing

## Surface-Blast Design

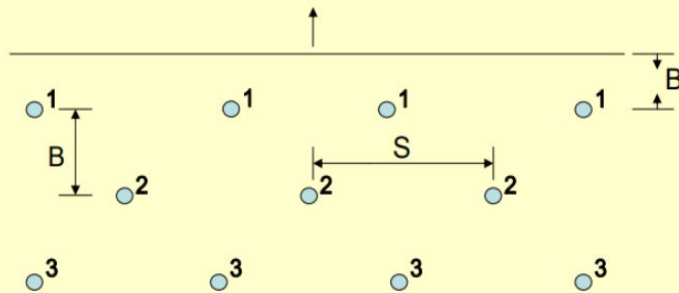

- SPACING - In blasting, the distance between boreholes or charges in a row
- Apparent burden - is the distance between the shot's first row and the highwall or free face and the distance between all subsequent rows running parallel to the face.

# True Burden and Spacing

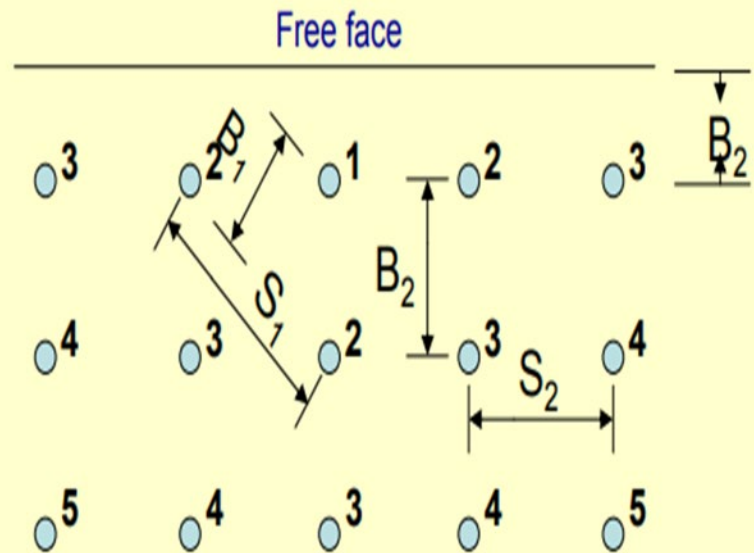

Numbers indicate firing sequence ( $B_1$  = true burden;  
 $B_2$  = apparent burden;  $S_1$  = true spacing;  $S_2$  = apparent spacing).

- True burden, on the other hand, is defined as the distance between rows as these are delineated by the drill pattern and the delay timing associated with it.  
(Note as well that, as the example here shows, a comparable distinction is also made between “apparent spacing” and “true spacing.”)

# Rock Volume Formulas

- Cubic Yards per Hole and per Blast.
- $\text{Yard}^3 = \text{Burden} \times \text{Spacing} \times \text{Hole Depth} \div 27$
- $\text{Yard}^3 \text{ per Blast} = \text{Burden} \times \text{Spacing} \times \text{Hole Depth} \div 27 \times \text{the Number of Holes in the Blast.}$
- $\text{Tons per Cubic Yard} = \text{Weight of One Cubic Foot of Rock} \times 27 \div 2000$   
( limestone average 160 lbs/ft<sup>3</sup>, sandstone average 155 lbs/ft<sup>3</sup> )
- Subdrilling – to drill a blast hole deeper than the planned excavation line.
- Any subdrilling is not considered as part of the height in calculating Yardage. **For The Blaster Examination.**

# Problem #1

- The blast pattern is 12 foot burden by 12 foot spacing drilled 30 feet in depth. Number of holes drilled 25. Material blasted is limestone at 160 lbs / ft<sup>3</sup>.
- Cubic yards per hole?
- Cubic yards for the blast?
- Tons per Yards<sup>3</sup> ?
- Tons for the blast?

# Solution

- $\text{Yards}^3 = 12' \times 12' \times 30' \div 27 = 160 \text{ yards/hole}$
- $160 \times 25 = 4000 \text{ yards/blast}$
- $160 \text{ lbs} \times 27 \div 2000 = 2.16 \text{ tons/yard}^3$
- $2.16 \times 4000 = 8640 \text{ tons}$

# Problem # 2

A trench line is drilled on a 5 foot by 5 foot blast pattern. The holes are drilled to a depth of 8 feet. The number of holes drilled 125. Material blasted is limestone at 160 lbs / ft<sup>3</sup>.

- Cubic yards per hole?
- Cubic yards for the blast?
- Tons per cubic Yards ?
- Tons for the blast?

# Solution

- Cubic yards per hole, yards/hole  $\text{Yards}^3 = 5' \times 5' \times 8' \div 27 = 7.4$
- Cubic yards for the blast,  $27 \times 125 = 925 \text{ yards/blast}$
- Tons per cubic Yard, tons/yard<sup>3</sup>  $160 \text{ lbs} \times 27 \div 2000 = 2.16$
- Tons for the blast,  $2.16 \times 925 = 1998 \text{ tons}$

# Problem #3

- A blast is drilled 38 feet deep on a bench with a face height of 35 feet. 36 holes are drilled with a 5.5" bit on a 11 X 13 pattern.
- What is the cubic yardage per hole?
- What is the cubic yardage for the blast?

# Solution

38 ft. hole – sub drill of 3ft. = 35 ft. borehole depth

$$\text{Yardage}^3 = 11 \times 13 \times 35 \div 27$$

# Answer

$185.37 \text{ yd}^3$

Or rounded to  $185.4 \text{ yd}^3$

# ANFO Properties

Ammonium Nitrate Prill (94 %) to Fuel Oil (6 %) mix

- **Ammonia** - is a colorless, pungent gas composed of nitrogen and hydrogen ( $\text{NH}_3$ ).
- We generally think of it as a gas shipped under pressure as a liquid for use as a fertilizer.
- **Ammonium Nitrate** is relatively simple - Ammonia gas is reacted with nitric acid to form a concentrated solution.
- So how is Prill made from this - Prill forms when a drop of concentrated ammonium nitrate solution (95 percent to 99 percent) falls from a tower and solidifies.

While ammonium nitrate (AN) is also used extensively in the formulation of some high explosives, emulsions, and water gels, this discussion centers on its most common form, that of a prill to be mixed with fuel oil and used as a blasting agent.

By its definition as a blasting agent, ANFO is not "cap sensitive" and therefore requires a high explosive "primer" to initiate it.

These "prills" are porous, spherically shaped pellets, typically between 6 and 20 mesh U.S. standard screen size. The porosity of the prills is carefully controlled during the manufacture of the AN prills to ensure that they will absorb the correct amount of fuel oil. This porosity is one difference between the blasting grade AN prill and the more common fertilizer grade AN used in agriculture.

Another distinction is that the agricultural prill is much harder and has a higher density.

Additionally there are different types and amounts of coatings used on the blasting grade prills to add a certain amount of water resistance, thereby preventing caking and allowing them to flow freely. The caking of this prilled material is due to the AN prill's tendency to absorb moisture from its environment. Without such a coating, AN will attract moisture from the humidity of the air and in effect dissolve itself.

Once the prills are on site, they are subject to a phenomena called cycling. Cycling is a process whereby AN undergoes a change in its crystal structure in response to a change in temperature. There are two temperatures, at which AN goes through this cycling, 0° F and 90° F ( -18° C and 32° C ). Both of these temperatures are readily reached by products stored in outdoor magazines during the winter and summer in most areas. The actual "cycling" occurs when the temperature fluctuates above and below these critical temperatures. The effect of this change in crystalline structure is to break the prills down into smaller and smaller particles. This increases the density of the ANFO, and also diminishes the prills' water resistance, which is supplied by its coating. Over time, this will result in the AN drawing moisture from the humidity in the air, dissolving and reforming as larger crystals (Caking).

Information from the U. S. Geological Survey showed that during the 1990's, ANFO blasting agents and unprocessed ammonium nitrate accounted for more than 80% of the total industrial explosives sold for consumption in the United States.

Theoretically, at zero oxygen balance the gaseous products of detonation are H<sub>2</sub>O, (water) CO<sub>2</sub>, (carbon monoxide), and N<sub>2</sub> (nitrogen)

However, its performance as an explosive does vary based on a number of factors, some of which are controllable, while others are not. These factors are:

1. The physical characteristics of the prills, such as size, shape, porosity and density.
2. The distribution and proportion of the fuel oil when mixed with the prills.
3. The diameter of the borehole and degree of confinement.
4. The size and type of primer and the priming procedure used.
5. The exposure to water in the boreholes. (Can slow the speed of detonation, causing an incomplete burn. Resulting in the production of nitrogen oxides and carbon monoxide; the gaseous products of incomplete combustion.) Generally seen as orange smoke.

# Detonation Velocity

- Detonation velocity is the speed at which the detonation front moves through a column of explosives.
- It ranges from about 5,500 to 25,000 fps for products used commercially today.
- A high detonation velocity gives the shattering action that many experts feel is necessary for difficult blasting conditions,
- Whereas low-velocity products are normally adequate for the less demanding requirements typical of most blasting jobs.
- Detonation velocity, particularly in modern dry blasting agents and slurries, may vary considerably depending on field conditions.
- Detonation velocity can often be increased by the following

- 1. Using a larger charge diameter.
- 2. Increasing density (although excessively high densities in blasting agents may seriously reduce sensitivity).
- 3. Decreasing particle size (pneumatic injection of ANFO in small diameter boreholes accomplishes this).
- 4. Providing good confinement in the borehole.
- 5. Providing a high coupling ratio (coupling ratio is the percentage of the borehole diameter filled with explosive).
- 6. Using a larger primer (this will increase the velocity near the primer but will not alter the steady state velocity).

# Detonation pressure

- The pressure associated with detonation moving through an explosive, measured in kilobars or pound /in<sup>2</sup> is defined as detonation pressure. Detonation pressures of explosives range from 10 to over 140 Kilobars (1 Kilobar = 14,504 psi).
- Detonation pressure is more dependent on detonation velocity than specific gravity. A high detonation pressure is necessary when blasting hard, dense rock. In softer rock, a lower pressure is sufficient.
- Water resistance is the ability of an explosive product to withstand exposure to water without either losing power or becoming desensitized.
- The detonation pressure of explosive products that have been exposed to water in blast holes is far less than that of mixtures placed in dry holes if the product is not manufactured with water-resistance properties or protected from water intrusion.

# Problem # 3

A bulk truck that can hold 8,000 lbs of AN will need to hold how many gallons of diesel fuel for a 6% (by weight) mixture of ANFO? Diesel weighs 7 lbs/gallon:

- A. About 132 gallons
- B. About 68.8 gallons
- C. About 46 gallons
- D. About 685 gallons

# Solution

Weight of AN x Percentage of diesel fuel (by weight) ÷ weight  
of diesel fuel

$$8,000 \times 0.06 \div 7 = 68.8 \text{ gallons}$$

# Problem # 4

- A bulk truck that can hold 20,000 lbs of AN will need to hold how many gallons of diesel fuel for a 6% (by weight) mixture of ANFO?
- Diesel weighs 7 lbs/gallon.

$$20,000 \times 0.06 \div 7 =$$

172 gallons

# Specific Gravity

- The ratio of the density of a substance to the density of a standard, usually water for a liquid or solid, and air for a gas.
- If Water has a specific gravity of 1(one)
- We generally think of ANFO having a Specific gravity 0.85 g/cm<sup>3</sup>.
- Density(g/cm<sup>3</sup>) = wt. cup & explosives-cup wt.  
wt. cup & water- cup wt.

# Loading Density (LD)

LD = lbs explosives per foot of bore hole.

How do we determine Loading Density.

0.3405 times the explosive density, times the bore hole diameter squared.

$$LD = 0.3405 \times \text{density g/cm}^3 \times \text{bore hole diameter}^2 \text{ (in)}$$

# Problem # 5

- We have a 3 inch bore hole, our specific gravity is  $0.82 \text{ g/cm}^3$ .
- What is our loading density ?

# Solution

$$0.3405 \times 0.82 \text{ explosive density} \times 3^2 \text{ bore hole diameter squared} =$$

2.5 pounds of explosives / foot of bore hole

# Problem # 6

We have a  $7 \frac{7}{8}$  inch bore hole, our specific gravity is  $1.30 \text{ g/cm}^3$  what is are loading density (lb/ft) ?

# Solution

$$0.3405 \times 1.30 \times 7.875^2 =$$

Answer

27.45 lb/ft

# Determining Stemming

Stemming = 0.5 to 1.0 x the burden.

Typically 0.7 x burden.

# Problem # 7

For an initial blast design, where 5 1/8 inch holes are drilled on a 10 ft. x 10 ft. pattern. What would be the typical stemming height?

- A. 5 ft.
- B. 10 ft.
- C. 7 ft.
- D. 14 ft.

# Solution

0.7 typically x 10 feet of burden =

7 feet of stemming

# Problem # 8

For an initial blast design, where  $7 \frac{7}{8}$  inch holes are drilled on a 21 ft. x 21 ft. pattern. What would be the typical stemming height?

# Solution

$$0.7 \times 21 =$$

Answer

14.7 feet of stemming

# Powder Column

- Powder Column = Depth Of Hole – Stemming.

# Problem # 9

- The blast hole is 55 in depth the stemming length is 9.
- What is the powder column?

# Solution

- 55 depth of hole – 9 length of stemming =  
46 foot powder column.

# Charge Weight

## (Loading Factor)

- Charge Weight = Powder column x the loading density.
- Any subdrilling is included in the powder column since subdrilling is loaded.

# Problem # 10

- The blast hole is drilled 30 feet in depth. Loaded with 21 feet ANFO having a loading density of 5.5 lbs/ft.
- What is the charge weight?

# Solution

- 21 feet x 5.5 lbs = 115.5 lbs

# Problem # 11

- The blast hole is drilled 8 feet in depth. Loaded with 5 feet ANFO having a loading density of 2.5 lbs/ft.
- What is the charge weight?

# Solution

- 5 feet x 2.5 loading density =

# Answer

12.5 lbs

# Powder Factor

- Powder Factor = Powder Per Hole ÷ rock volume per hole.

# Problem # 12

- The blast is drilled on a 12' x 12' pattern to a depth of 20 feet. Each hole has a charge weight of 150 lbs.

What is are powder factor?

# Solution

- Powder per hole = 150 lbs
- Rock volume =  $12 \times 12 \times 20 \div 27 = 106.7$
- $150 \div 106.7 = 1.4$  powder factor

# Problem # 13

- The blast is drilled on a 5' x 5' pattern to a depth of 10 feet with 3 feet of subdrilling. Each hole has a charge weight of 12 lbs.
- What is are powder factor?

# Solution

- $5' \times 5' \times 7' \div 27 = 6.5^3$  yds.
- 12 lbs powder column

# Answer

$$12 \div 6.5 = 1.8 \text{ powder factor}$$

# Problem # 14

5 1/2-inch diameter holes are to be drilled on a 10 ft. x 10 ft. pattern. Holes will be 25 feet deep with 7 feet of stemming material. Holes are to be loaded with ANFO (specific gravity = 0.85).

What is the cubic yards per blast hole?

What is the powder column?

What is the loading density?

What is the charge weight?

What is the powder factor

cubic yards per blast hole

- $10 \times 10 \times 25 \div 27 = 92.6^3 \text{ yds.}$

## powder column

- $25' - 7' = 18'$  powder column

loading density

- $0.3405 \times 0.85 \times 5.5^2 = 8.75 \text{ lbs/ft}$

# charge weight

- $18 \times 8.75 = 157.5 \text{ lbs}$

# powder factor

- $157.5 \div 92.6 = 1.7$  powder factor

# Scale distance

- Scaled Distance (SD) is a scaling factor that relates blast effects from various charge weights of explosive at various distances.
- Scaled distance is calculated by dividing the distance to the structure of concern by the square root of the weight of the explosive material.
- $SD = \text{Distance} / \sqrt{\text{max lbs/delay}}$

# Problem # 15

What the scale distance if the nearest structure is 500 feet, total pounds detonated per delay is 33?  
Is this blast legal at a scale distance of 50?

# Solution

500 feet  $\div$   $\sqrt{33}$  lbs = 87.03 scale distance

So it is greater than 50?

# Problem # 16

- A blast with 50 holes is loaded with 126 pounds of explosives per hole. A historic structure is 1100 feet away with a ground vibration limit of 0.50 in/s. What is the maximum number of holes that can be detonated in any one delay period? if the blast is designed to a scaled distance of 90.

# Solution

- $1100 \text{ feet} \div \sqrt{126 \text{ lbs}} = 98 \text{ scale distance}$
- $W = (d/90)^2 \quad (1100 \text{ feet} \div 90)^2 = 149 \text{ lbs / delay}$
- We could detonate 1 hole / delay

# Electronic detonators

- IME recommended wait time for electronic detonators is 30 minutes in the event of a misfire.
- As compared to wait time for electric blast caps of 15 minutes.
- Can you use logger/controller from different manufacturers?
- The simple answer is **No**. Many electronic systems products made by different manufacturers look alike but should not be mixed within a blast.
- As a blaster you should not use a system you are not familiar with nor should you design a blast for a project that you have no prior experience in.  
(example underground rock quarry to surface coal mining)

# Blast Affects

## Vibration Energy

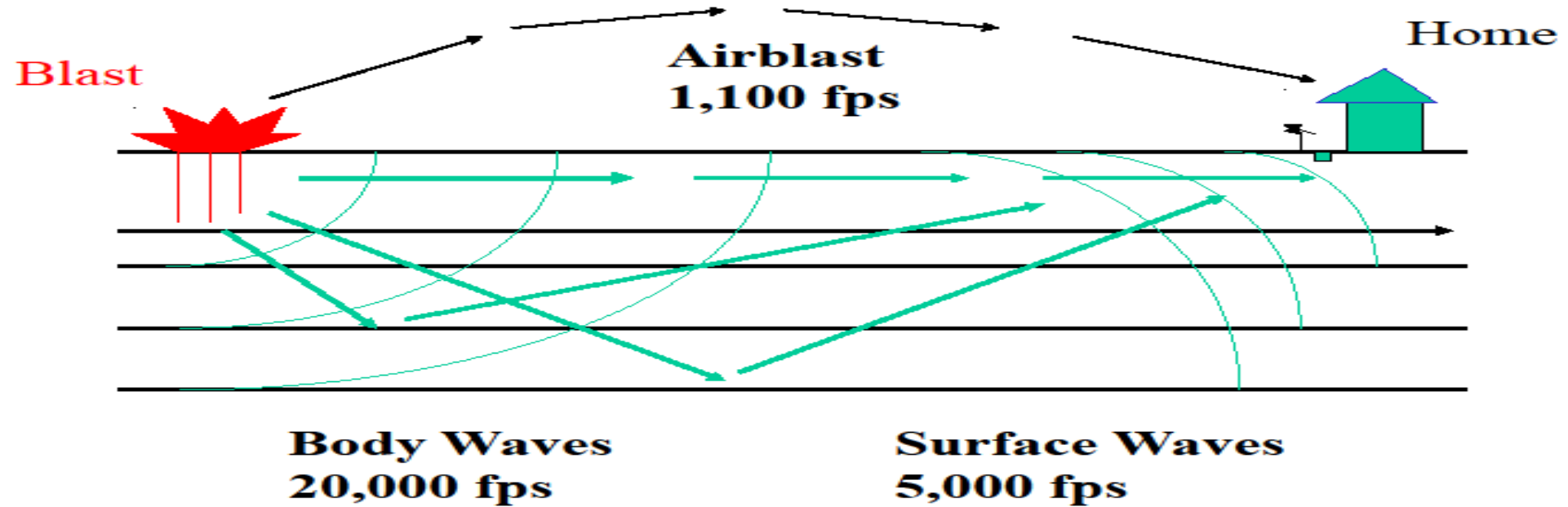

# Ground Vibration

- 805 KAR 4:020 Blasting Standards
- Section 1. Blasting Standards. (1) In all blasting operations, except as hereinafter otherwise provided, the maximum **peak particle velocity (PPV)** of the ground motion in any direction shall not exceed two (2) inches per second at the immediate location of any dwelling house, public building, school, church, commercial or institutional building.
- Particle Velocity - A measure of ground vibration. Describes the velocity at which a particle of ground vibrates when excited by seismic waves.
- The maximum PPV is The largest measurement of vibration in any one of three mutually perpendicular directions identified as transverse, vertical, and longitudinal

# Monitoring ground vibrations



- PPV is measured in 3 mutually perpendicular directions
- Longitudinal (or Radial) toward the blast.
- Transverse- at a right angle to the radial
- Vertical-up and down

# Seismic Monitoring

- Read the instruction manual and be familiar with the operation of the instrument.
- Always point the radial channel in the direction of the blast.
- Properly record the blast location (**the nearest hole to the nearest corner of the controlling structure**) and seismograph position in latitude and longitude on the blast record.
- Properly record the seismograph measurements by attaching a copy of the report to the blast record and saving the digital information from the seismograph.
- Read and follow the ISEE Field Practice Guidelines for Blasting Seismographs.

# Blasting Seismograph Report

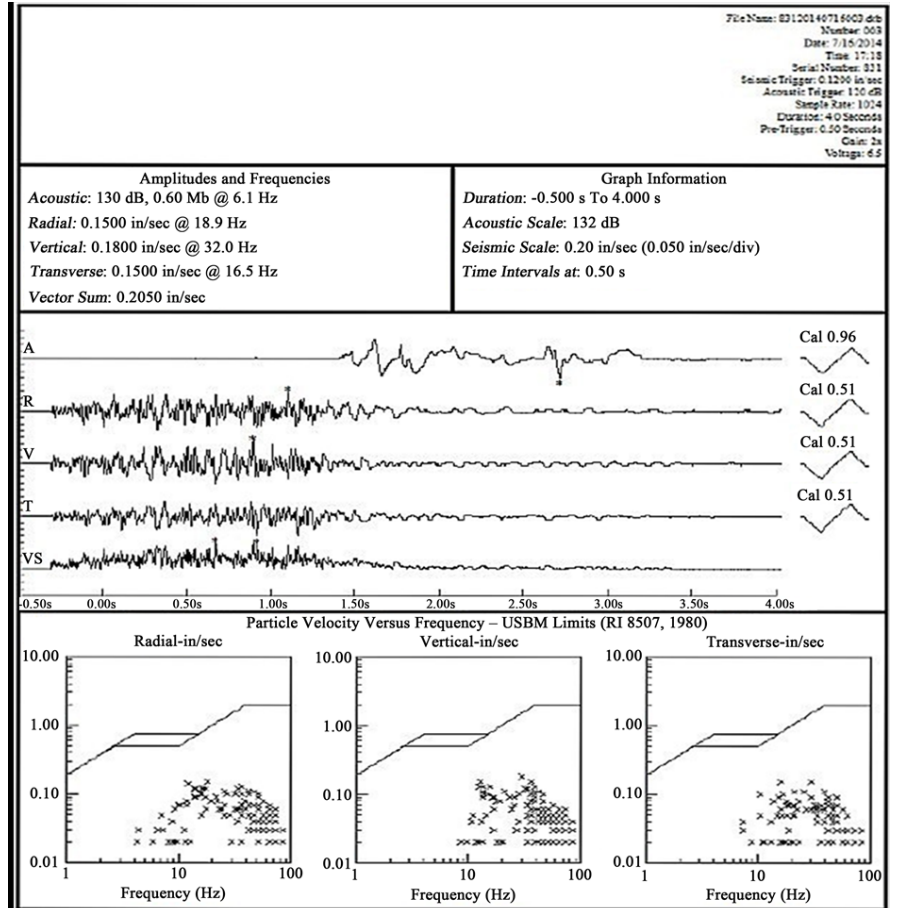

# What are you looking at on a seismograph Report.

1. The input information (Date, Time, Trigger Levels, Location, Calibration Date, along with other settings)
2. The wave forms from the 4 channels. (Acoustic, Radial, Vertical and Transverse, sometimes you will see a 5<sup>th</sup> channel for vector sum)
- 3 The results from the 4 channels.
4. The calibration Pulse.
5. Z-Curve plotted for each of the 3 ground channels.

The location of this information will vary with manufacturers but all reports contain the same information.

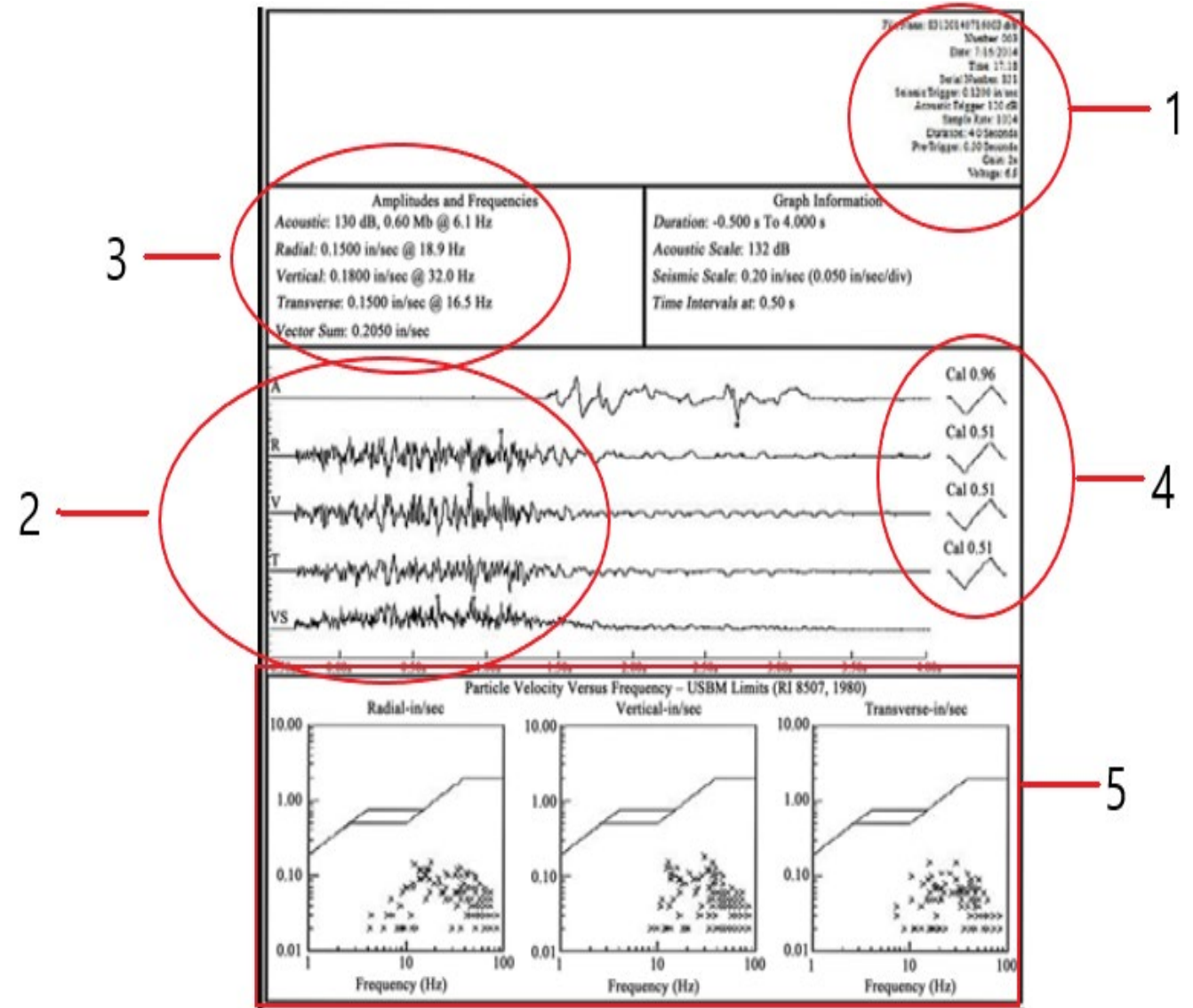

# Z Curve

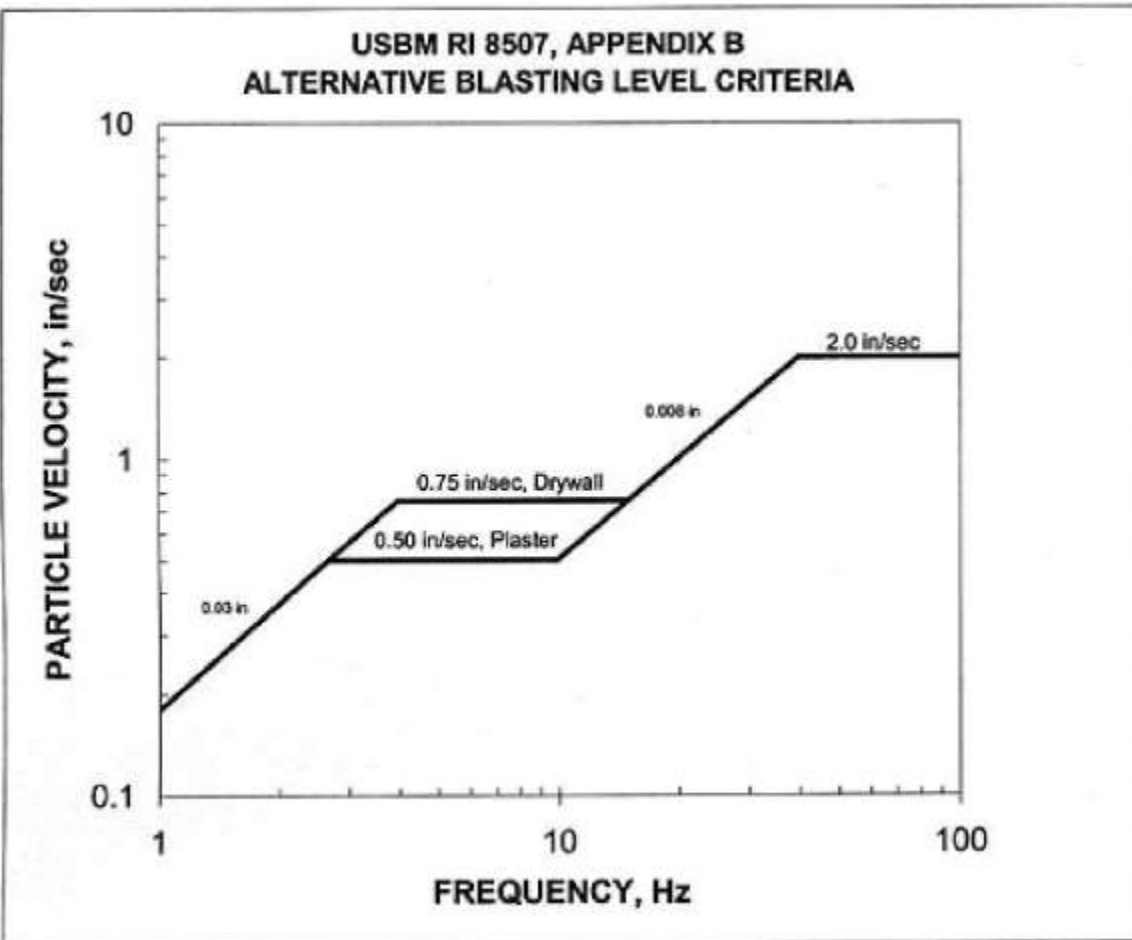

- Particle velocity- how fast the particles move. This rate is expressed in inches per second
- Frequency - The number of oscillations per second that a particle makes when under the influence of seismic waves, measured in Hertz
- A house natural frequency is 2-20 Hz.
- Damage is most likely at 4-12 HZ

# Peak Particle Velocity (PPV) Predictions

- Predicted PPV =  $K (SD)^a$  where
- $K$  = site constant (Average 160)  $a$  = slope (Normal-1.60)
- General Formula is  $PPV = 160(SD)^{-1.6}$  and is considered the best fit, it was developed by DuPont.

# Problem # 17

- Nearest structure is 1000 feet from the blast site. The maximum pounds of explosives per delay is 325. Using the DuPont formula what is the expected PPV for the structure?
- $PPV = 160(SD)^{-1.6}$

# What is the Scale Distance

$$SD = \text{Distance} \div \sqrt{\text{max lbs/delay}}$$

$$SD = 1000 \div \sqrt{325}$$

$$SD = 55.5$$

$$PPV = 160 \times (55.5)^{-1.6}$$

Expected PPV = 0.26 in / s

# Problem # 18

- Nearest structure is 2500 feet from the blast site. The maximum pounds of explosives per delay is 1100. Using the USBM worse case formula what is the expected PPV for the structure?
- $PPV = 438(SD)^{-1.52}$

# Scale Distance

$$SD = 2500 \div \sqrt{1100}$$

$$SD = 75.4$$

$$PPV = 438 \times (75.4)^{-1.52}$$

Expected PPV = 0.61 in/s

# Determining Constant for PPV Prediction

- Predicted “a” constant =  $\text{Known PPV} \div (\text{SD})^a$
- Where the known PPV is the seismograph reading.
- “a” is the slope.

# Problem # 19

- The nearest structure is 1500 feet, the pounds per delay is 250. The known PPV 0.25 in/s. General Formula is  $PPV = 160(SD)^{-1.6}$  and is consider the best fit, so we will use a negative slope of 1.6
- $K = 0.25 \div (94)^{-1.6}$
- $K = 358$  (new constant)
- Using the new constant you can predict your PPV
- $PPV = 358 \times (94)^{-1.6}$
- $PPP = 0.249$  in/sec

# To Calculate The PPV At A Point Away From The Seismograph

- $V = V_0 (D_0 \div D)^{1.5}$
- $V$  = vibration at point in question
- $V_0$  = PPV at the graph
- $D_0$  = distance to the graph
- $D$  = distance to the point in question

# Problem # 20

- The structure in question is 1500 feet from the blast area, the seismograph is located 600 feet from the blast. The Max PPV at the seismograph is 0.49 in/s.
- What is the expected PPV at the structure located 1500 feet from the blast area?
- $V = 0.49 \times (600 \div 1500)^{1.5}$

# Solution

- 0.12 in/s

# Air Blast

Air overpressure (blast) travel at 1100 feet per second

Air blast is measure in pounds per square inch (psi) and converted to linear scale decibels (dBL)

The use of decibels measuring airblast overpressure can lead to misinterpretation of ratios of airblast pressures because of the logarithmic function. For example, for a pressure ratio of 2, the decibel level only increases by  $20 \text{ Log } (2) = 6 \text{ dB}$ . Thus, an increase in overpressure by only 6 dB results in a doubling of the actual pressure magnitude.

# Blast design and Delay timing

- Blast designs are base on parameters previously discussed
- Borehole diameter
- Borehole length
- Burden
- Spacing
- Stemming
- Loading density
- Delay timing is key to control of fragmentation, vibration and flyrock.
- Neither fragmentation or movement occur instantaneously timing is critical to maintain the balance between confinement and relief.
- Delay timing is designed to direct rock movement.

# Problem # 21

- A blaster plans to row shoot a production blast 4 rows long with a total of 24 holes using 17ms and 42 ms. surface delays.
- How many holes will detonate per 8ms. delay?

----- 17 ms

—————> 42 ms

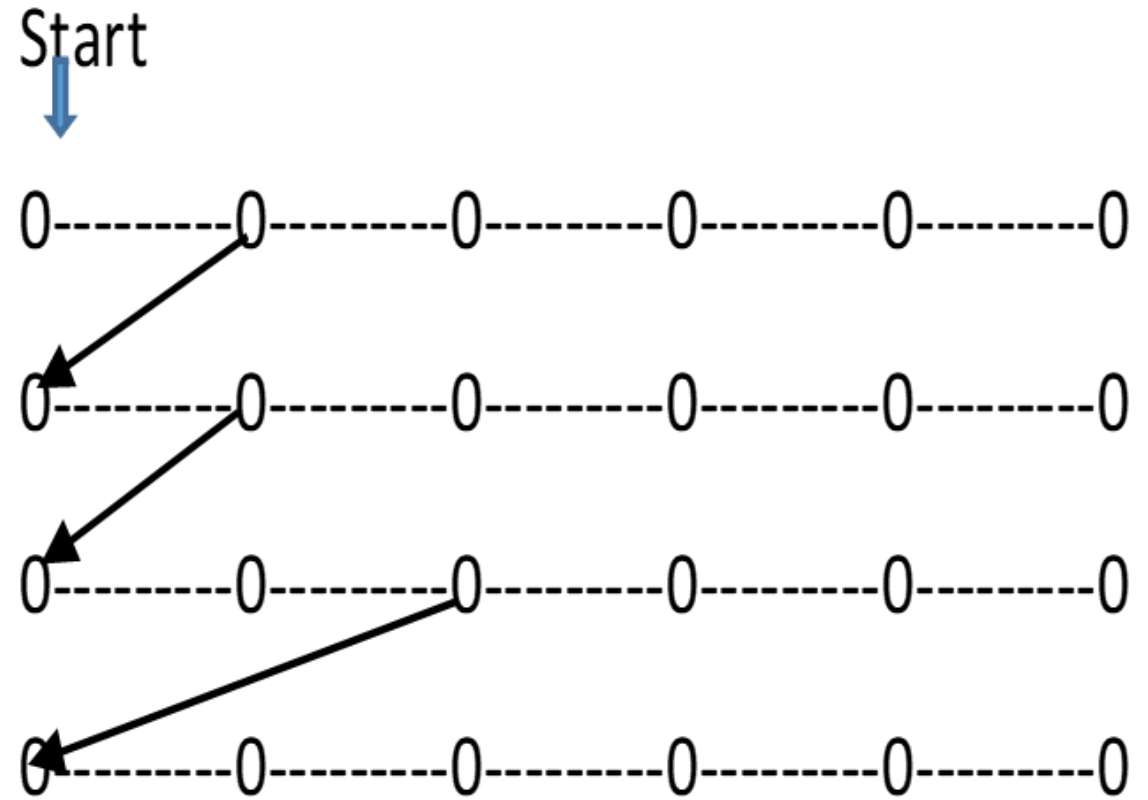

# Solution

0	17	34	51	68	85
59	76	93	110	127	144
118	135	152	169	186	203
194	211	228	245	262	279

1 holes per 8ms. delay

# Problem # 22

- A blaster plans to detonate a 30 hole production blast on a construction project. The blaster will need to deck this particular shot. The blaster will use 475ms. and 500 ms. downhole delays. The blaster will use 9ms. and 100 ms. surface delays
- What will the timing for this shot be?
- How many delays per 8ms. will detonate?

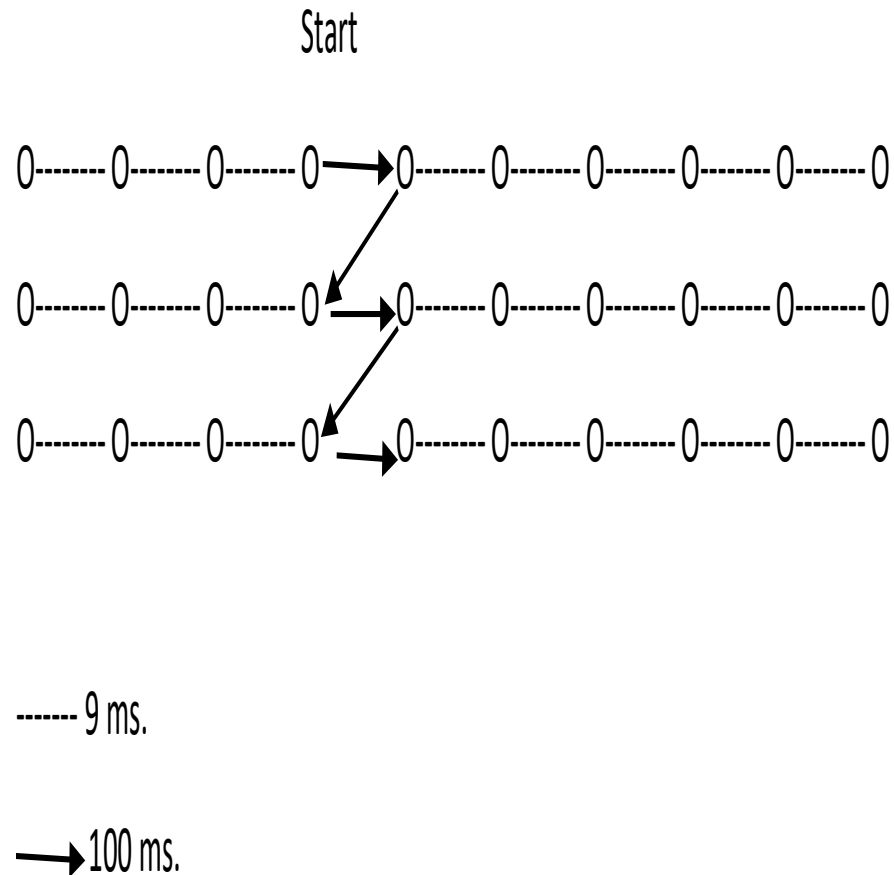

# Solution

- 502 493 484 475 575 584 592 602 611 620
- 527 518 509 500 600 609 618 627 636 645
- 
- 
- 702 693 684 675 775 784 793 802 811 820
- 727 718 709 700 800 809 818 827 836 845
- 
- 
- 902 893 884 875 975 984 993 1002 1011 1020
- 927 918 909 900 1000 1009 1018 1027 1036 1045
- 
- 2 decks per 8ms

# Problem # 23

- A trench blast is drilled with a 3 inch bit on a 5 foot by 5 foot pattern 10 feet deep consisting of 50 hole. The delay design is 2 row with 25 holes per row. The blaster will use a non-electric EZ det detonator with 25 ms surface delay, 350 ms down hole delay and a 42 ms surface delay between rows. The blaster will hold 3 feet of crushed stone stemming with a single powder column. The hole will be loaded using 50 pound bags of ANFO having a density of 0.82 and a ¼ pound primer. The nearest structure is 250 feet from the nearest blast hole.
- What is the cubic yards per hole and per blast?
- What is the loading density?
- What is the charge weight per hole?
- How many bags of ANFO is needed to load the blast?
- What is the powder factor for this blast?
- What is the number of holes per delay period detonated?
- What is the total firing time for this blast?
- What is the scale distance for this blast?
- What is the predicted peak particle velocity for this blast? (Use Average Expected)
- How many holes per delay can legally be detonated in the Commonwealth of Kentucky?

# Cubic Yards

$$5 \times 5 \times 10 \div 27 = 9.25 \text{ yards / hole}$$

$$9.25 \times 50 = 462.5 \text{ total yards}$$

# Loading Density

$$0.3405 \times 0.82 \times 3^2 = 2.5 \text{ lbs / foot of bore hole}$$

# Charge Weight

$7 \times 2.5 = 17.5$  of ANFO / bore hole

$17.5 + .25 = 17.75$  lbs. total charge weight

# Bags of ANFO Needed

$$17.5 \times 50 = 875 \text{ lbs}$$

$$875 \div 50 = 17.5$$

Bags needed 18

# Powder Factor

$$17.75 \div 9.25 = 1.9$$

# Holes per Delay Period detonated

0-25-50-75-100-125-150-175-200-225-250-275-300-325-350-375-400-425-450-475-500-525-575- 600-625  
42-67-92-117-142-167-192-217-242-267-292-317-342-367-392-417-442-467-492-517-542-567-592-617-642

One hole per delay

Total time 642 ms

or

The number of millisecond in a second.

$$642 \div 1000 = 0.64 \text{ seconds}$$

# Scale Distance

$$250 \div \sqrt{17.75} = 59.4$$

# Predicted Peak Particle Velocity(PPV)

$$119 \times 59.4^{-1.52} = 0.24 \text{ in/s PPV}$$

# Kentucky has a SD Factor of 50

$$(250 \div 50)^2 = 25 \text{ lbs/delay}$$

One hole at a time may be detonated without the use of a seismograph.

**I dont always ask for  
questions after a  
presentation**

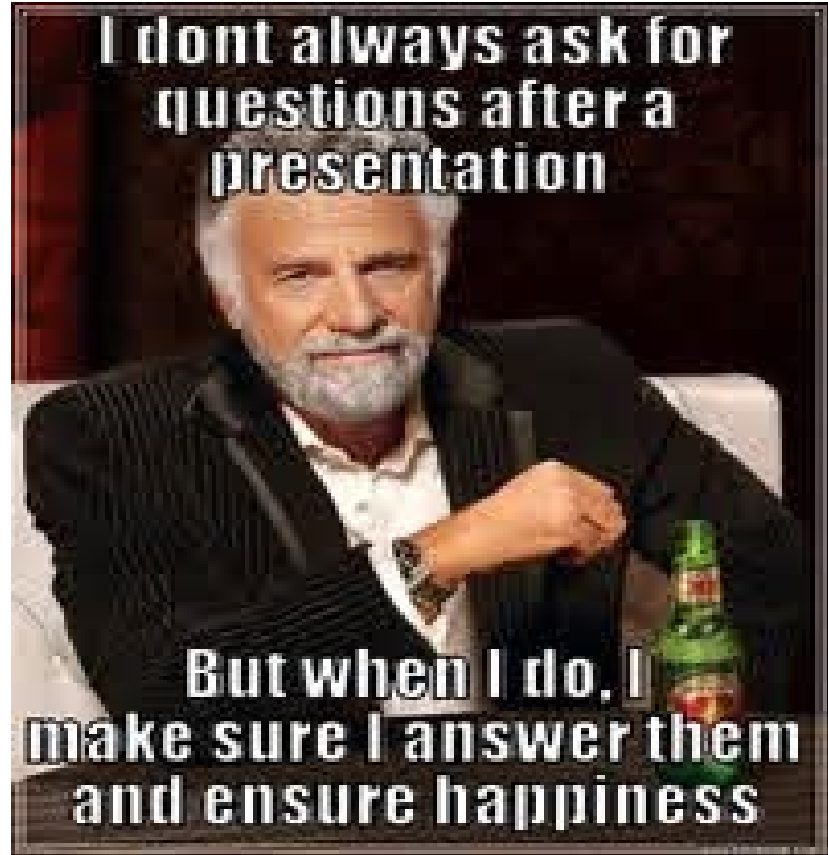
A meme featuring a man with a grey beard and hair, wearing a dark suit jacket over a light-colored shirt. He is sitting at a table with his arms crossed, looking directly at the camera with a slight, knowing smile. A green beer bottle is on the table in front of him. The background is dark and out of focus.

**But when I do, I  
make sure I answer them  
and ensure happiness**